

TRIMWEX

ONE SIDED BENCH GLUE SPREADER type GST and GZT
WERKBANK EINSEITIGE LEIMAUFTRAGMASCHINE Typ GST und GZT
INCOLLATRICI UNILATERALI DA BANCO, tipo GST e GZT
ENCOLLEUSE type GST et GZT
APLICADORES DE COLA UNILATERALES DE MESA TIPO GST y GZT

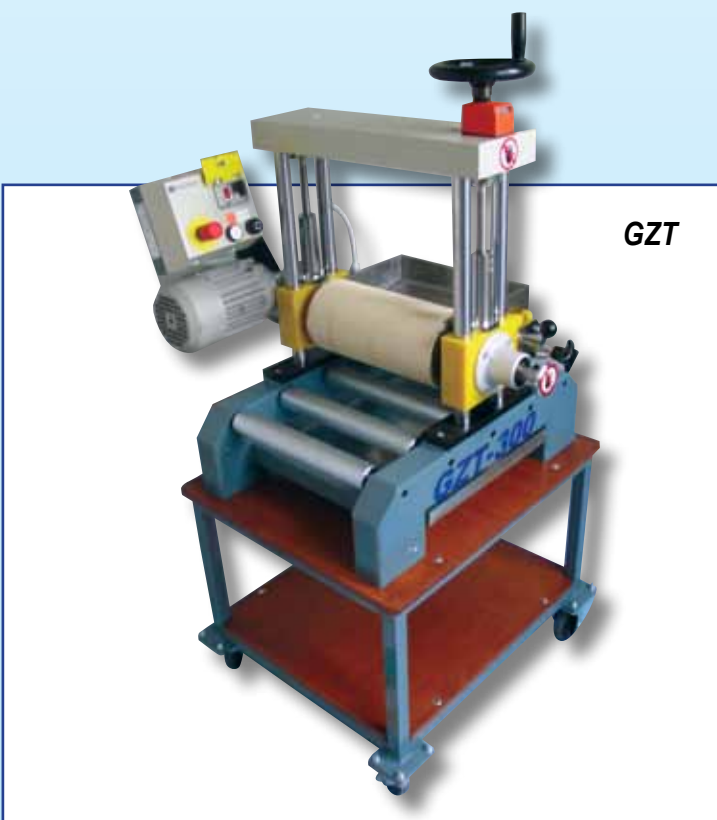
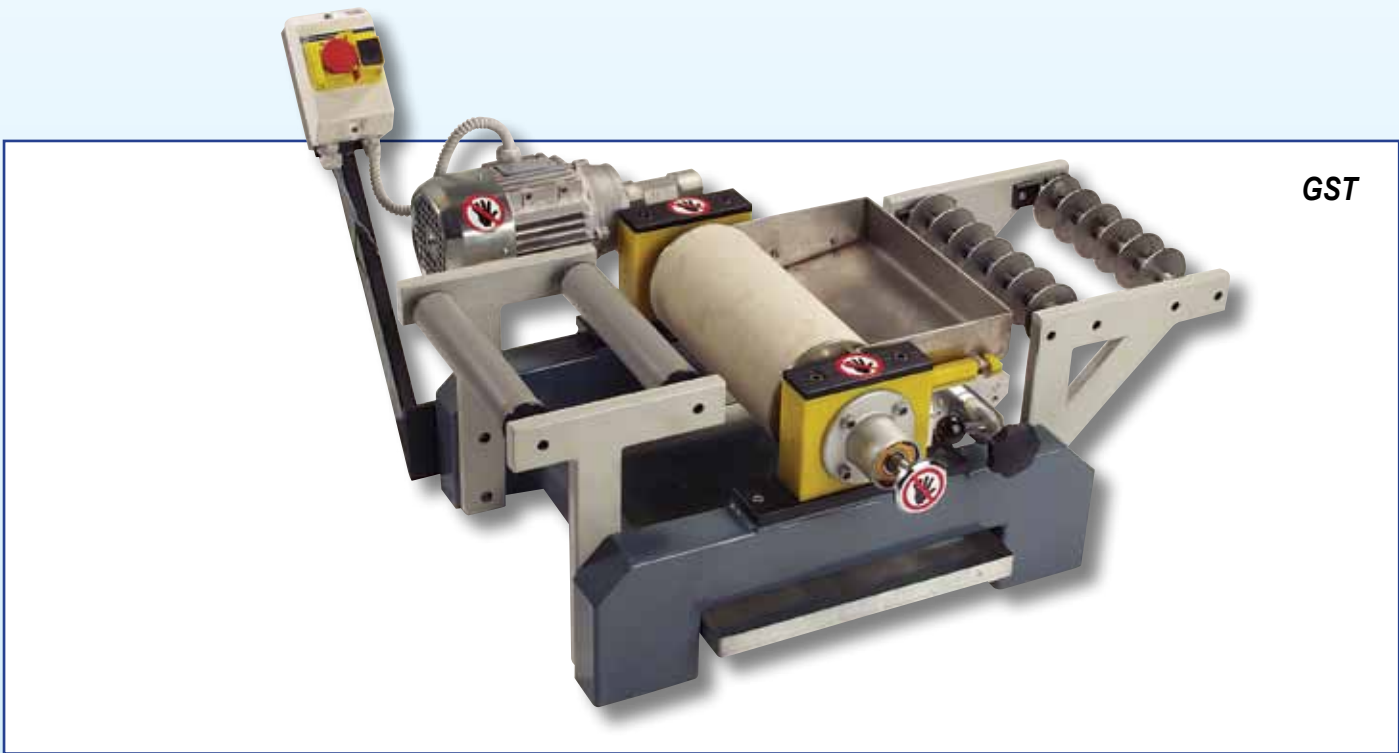

- Designed for one-side glue spreading of surfaces and edges on flat workpieces.
- Sie wird zum einseitigen Leimauftragen auf den Flächen von Elementen, die zu Platten und Profilen verleimt werden verwendet.
- L'incollatrice é adibita all'incollaggio unilaterale di elementi dritti (bordo o superficie)
- Encolleuse d'établi une face
- El aplicador de cola se usa para engomar una cara de las superficies y bordes de piezas lisas.

ONE SIDED GLUE SPREADER WITH CONVEYOR type GA

EINSEITIGE LEIMAUFTRAGMASCHINE MIT FÖRDERER Typ GA

INCOLLATICI UNILATERALI CON TRASPORTATORE tipo GA

ENCOLLEUSE D'ÉTABLI DEUX FACES type GA

APLICADORES DE COLA UNILATERALES CON TRANSPORTADORES tipo GA

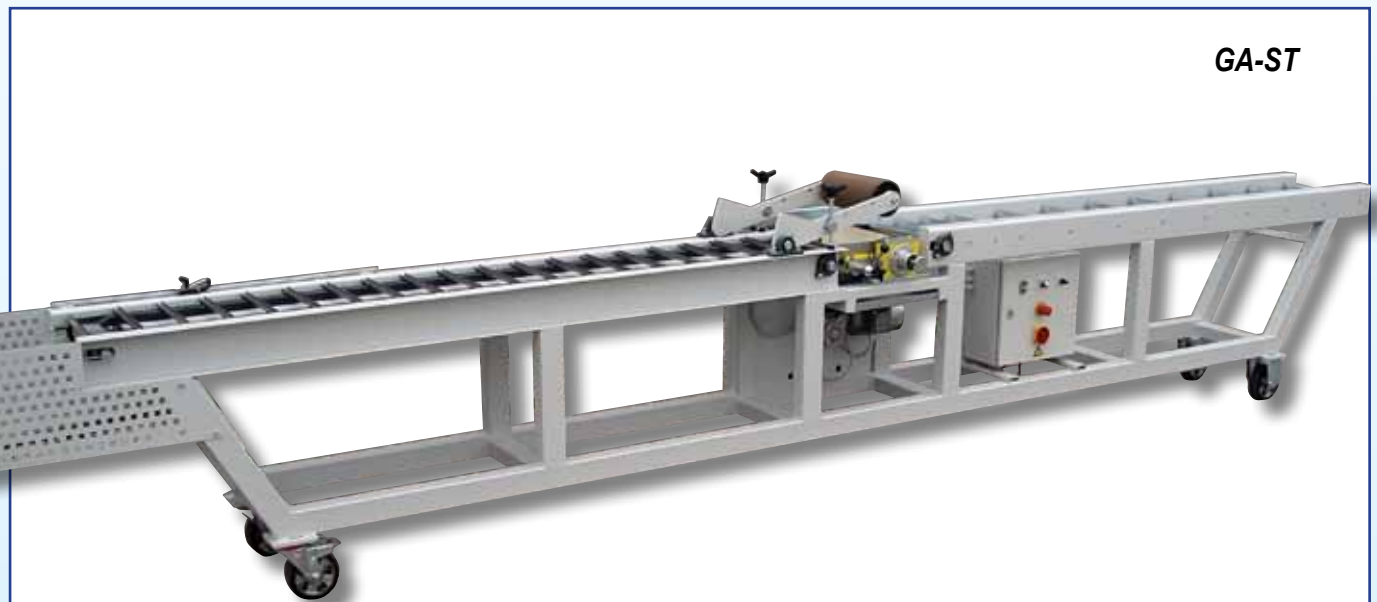

- Designed for one-side glue spreading of surfaces and edges on flat workpieces.
- Sie wird zum einseitigen Leimauftragen auf den Flächen von Elementen, die zu Platten und Profilen verleimt werden verwendet.
- L'incollatrice adibita all'incollaggio unilaterale di elementi diritti (bordo o superficie)
- Elle est utilisée pour l'encollage une face de bois pour plateaux ou profils
- El aplicador de cola se usa para engomar una cara de las superficies y bordes de piezas lisas.

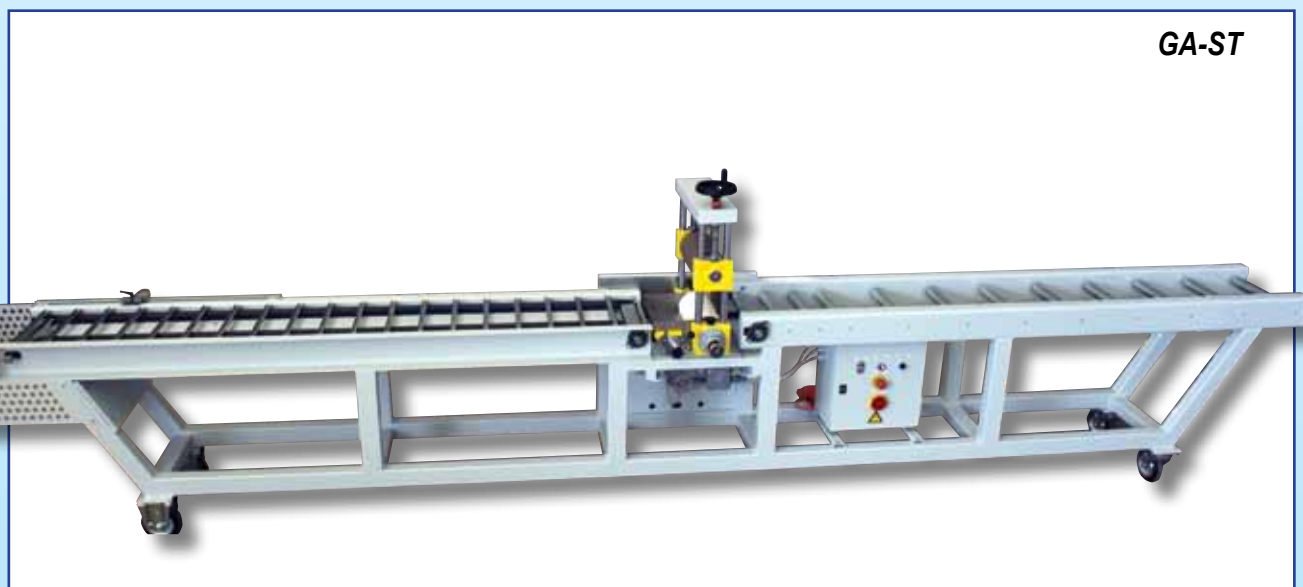



Technical data

- Working width of rubbered roller	200, 300, 400	mm
- Spreading roller diameter	140	mm
- Hardness of rubber	70	Shor
- Feeding speed	20 m/	min
- Connected power	0,25	kW
- The channel and spreading roller are easily removed from the machine during cleaning operation		
Infeed roller/lath conveyor, length	1500 – 3000	mm
Outfeed lath conveyor, length	1500 – 3000	mm

Option

- Top pressing roller
- Driven conveyors
- Protective cover
- Speed regulation
- Leading rollers for narrow workpiece
- protective net above channel for gluing short workpieces
- movable end switch on outfeed conveyor



Technische Daten

- Breite des gummierte Walzen	200, 300, 400	mm
- Durchmesser der Walzen	140	mm
- Gummihärt	70	Shor
- Leistung	0,25	kW
- Geschwindigkeit	20 m/min	
- der Leimbehälter und die Auftragwalze werden zum Reinigungszwecke einfach aus der Leimauftragmaschine ausgefahren		
Eingangsrollenförderer, Länge	1500 – 3000	mm
Ausgangleistenförderer, Länge	1500 – 3000	mm

Optionen

- obere Andruckwalze
- angetriebener Förderer
- Sicherheitshaube
- Geschwindigkeitsregelung
- Führungswalzen für schmale Elemente
- Schutzgitter am Behälter beim Verleimen von kurzen Elemente
- verstellbare Endschalter am Ausgangsförderer



Dati tecnici

- larghezza del rullo	200, 300, 400	mm
- diametro del rullo	140	mm
- durezza della gomma	70	Shor
- velocità del rullo	20 m/min	
- potenza installata	0,25	kW
- il montaggio e lo smontaggio sono estremamente semplici, in modo da garantire una pulizia rapida		
Transportatore d'entrata a tapparelle/rulliera	1500 – 3000	mm
Transportatore d'uscita a tapparelle	1500 – 3000	mm

Opzioni

- Rullo superiore di pressione
- Trasportatore motorizzato
- Coperchio di sicurezza
- Regolazione velocità
- Rulli di supporto per pezzi stretti
- Rete di protezione sulla vasca, per l'incollaggio di pezzi corti
- Finecorsa posizionato sulla rulliera d'uscita, regolabile manualmente



Caractéristiques techniques

- Largeur des rouleaux vulcanisés	200-300-400	mm
- Diamètre des rouleaux	140	mm
- Dureté	70	shor
- Puissance	0,25	kW
- Vitesse d'avance	20 m/min	
- Pour le nettoyage, le bac à colle et le rouleau encolleur sont amovibles.		
Table à rouleaux d'entrée	1500-3000	mm
Table à rouleaux de sortie	1500-3000	mm

Options

- Rouleau presseur dessus
- Transfert entraîné
- Capot de sécurité
- Régulateur de vitesse
- Rouleaux de guidage pour petites largeurs
- Grille de sécurité au bac pour petites longueurs
- Fin de course réglable sur table à rouleaux de sortie







Datos técnicos





- anchura operativa de rodillos engomadores	200, 300, 400	mm
- diámetro del rodillo	140	mm
- dureza de la goma	70	Shor
- velocidad	20 m/min	
- energía de conexión	0,25	kW
- desmontaje y montaje sencillos de la cubeta y del rodillo durante la limpieza		
Transportador de rodillo/listón de entrada, longitud	1500 – 3000	mm
Transportador de listón de salida, longitud	1500 – 3000	mm

Opción

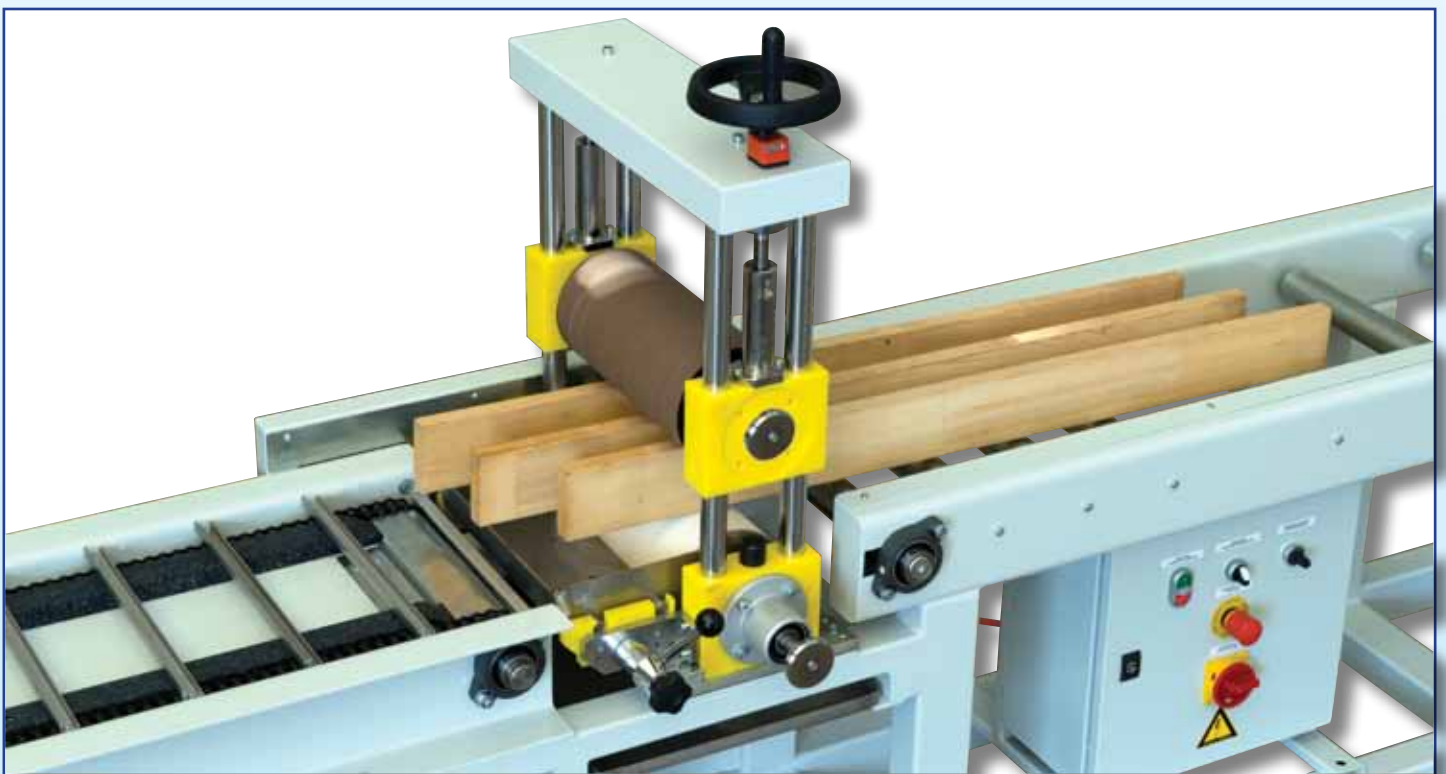
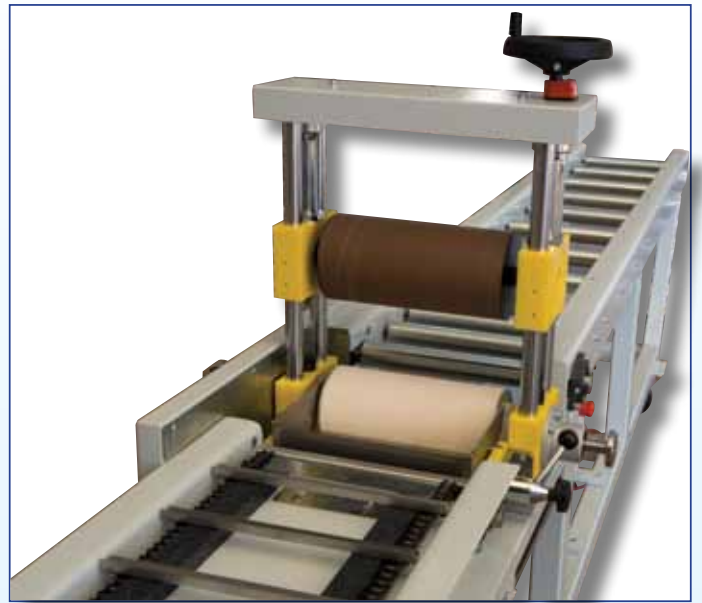



- Rodillo tensor superior
- Transportadores de impulsión
- Tapa protectora
- Regulación de la velocidad
- Rodillos guía para piezas estrechas
- rejilla protectora de la cubeta para engomados de piezas cortas
- interruptor final móvil en los transportadores de salida

-  Top pressing roller – heavy duty version
-  Obere Druckwalzen – schwere Auführung
-  Rullo di pressione inferiore – variante pesante
-  Rouleau presseur dessus - version lourde
-  Rodillo de presión superior- versión pesada













-  Top pressing roller – light version
-  Obere Druckwalzen – Light Version
-  Rullo di pressione superiore – variante leggera
-  Rouleau presseur dessus - version légère
-  Rodillo de presión superior - versión ligera



-  the channel and spreading roller are easily removed from the machine during
-  der Leimbehälter und die Auftragwalze werden zum Reinigungs zwecke einfach aus der Leimauftragmaschine ausgefahren.
-  Facile smontaggio e montaggio del cilindro e del rullo durante la pulizia
-  Montage et démontage du cylindre et du bac pendant le nettoyage
-  instalación y desmontaje fácil del rodillo y lavadero durante la limpieza



-  movable end switch on outfeed conveyor
-  verstellbare Endschalter am Ausgangsförderer
-  Finecorsa posizionato sulla rulliera d'uscita, regolabile manualmente
-  Fin de course réglable sur table à rouleaux de sortie
-  interruptor final móvil en los transportadores de salida

-  Leading rollers for narrow workpiece
-  Führungswalzen für schmale Elemente
-  Rulli di supporto per pezzi stretti
-  Rouleaux de guidage pour petites largeurs
-  Rodillos guía para piezas estrechas

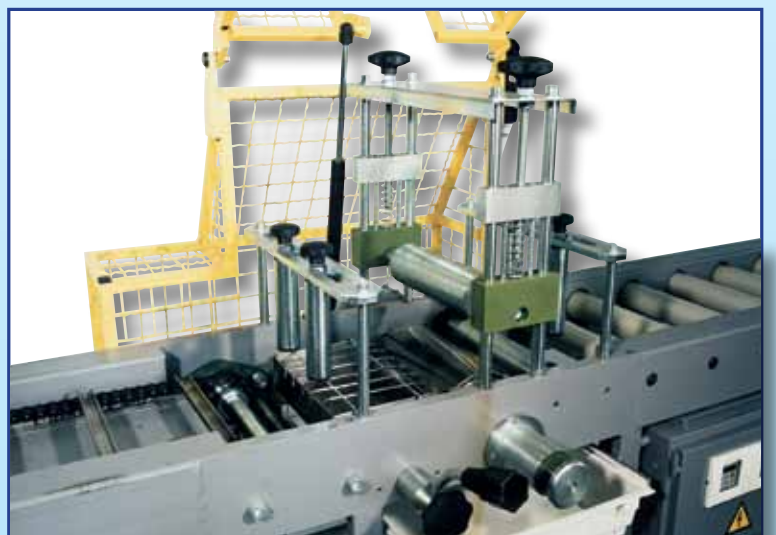



Technical data

- Working width of rubbered roller 200, 300, 400 mm
- Spreading roller diameter 140 mm
- Hardness of rubber 70 Shor
- Feeding speed 20 m/min
- Connected power 0,25 kW
- The channel and spreading roller are easily removed from the machine during cleaning operation



Technische Daten

- Breite des gummirte Walzen 200, 300, 400 mm
- Durchmesser der Walzen 140 mm
- Gummihärte 70 Shor
- Leistung 0,25 kW
- Geschwindigkeit 20 m/min
- der Leimbehälter und die Auftragwalze werden zum Reinigungszwecke einfach aus der Leimauftragmaschine ausgefahren



Dati tecnici

- larghezza del rullo 200, 300, 400 mm
- diametro del rullo 140 mm
- durezza della gomma 70 Shor
- velocità del rullo 20 m/min
- potenza installata 0,25 kW
- il montaggio e lo smontaggio sono estremamente semplici, in modo da garantire una pulizia rapida



Caractéristiques techniques

- Largeur des rouleaux vulcanisés 200-300-400 mm
- Diamètre des rouleaux 140 mm
- Dureté 70 shor
- Puissance 0,25 kW
- Vitesse d'avance 20 m/min
- Pour le nettoyage, le bac à colle et le rouleau encolleur sont amovibles.



Datos técnicos

- anchura operativa de rodillos engomadores 200, 300, 400 mm
- diámetro del rodillo 140 mm
- dureza de la goma 70 Shor
- velocidad 20 m/min
- energía de conexión 0,25 kW
- desmontaje y montaje sencillos de la cubeta y del rodillo durante la limpieza

Option

- Top pressing roller
- Driven conveyors
- Protective cover
- Speed regulation
- Leading rollers for narrow workpiece
- protective net above channel for gluing short workpieces
- movable end switch on outfeed conveyor

Optionen

- obere Andruckwalze
- angetriebener Förderer
- Sicherheitshaube
- Geschwindigkeitsregelung
- Führungswalzen für schmale Elemente
- Schutzgitter am Behälter beim Verleimen von kurzen Elemente
- verstellbare Endscharter am Ausgangsförderer

Opzioni

- Rullo superiore di pressione
- Trasportatore motorizzato
- Coperchio di sicurezza
- Regolazione velocità
- Rulli di supporto per pezzi stretti
- Rete di protezione sulla vasca, per l'incollaggio di pezzi corti
- Finecorsa posizionato sulla rulliera d'uscita, regolabile manualmente

Options

- Rouleau presseur dessus
- Transfert entraîné
- Capot de sécurité
- Régulateur de vitesse
- Rouleaux de guidage pour petites largeurs
- Grille de sécurité au bac pour petites longueurs
- Fin de course réglable sur table à rouleaux de sortie

Opción

- Rodillo tensor superior
- Transportadores de impulsión
- Tapa protectora
- Regulación de la velocidad
- Rodillos guía para piezas estrechas
- rejilla protectora de la cubeta para engomados de piezas cortas
- interruptor final móvil en los transportadores de salida

TRIMWEX, d.o.o.

Pot k skakalnici 9A
1210 LJUBLJANA - ŠENTVID
SLOVENIJA

tel.: +386 1 512 93 60
fax: +386 1 512 93 65
GSM: +386 41 706 610
E-mail: trimwex@siol.net
<http://www.trimwex.si>

