

Moulding guard TAPOA (CPS)

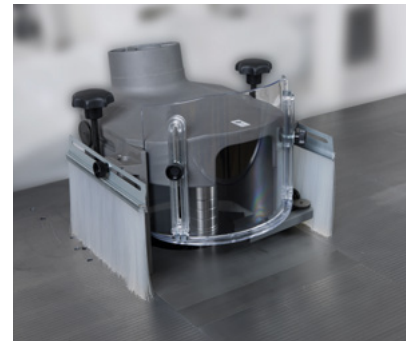

BowmouldMaster (Aigner)

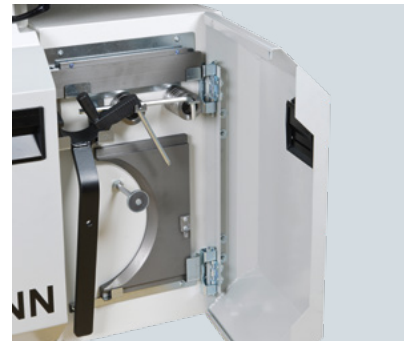

Tool deposit



Document holder



Safety light bar at the fence

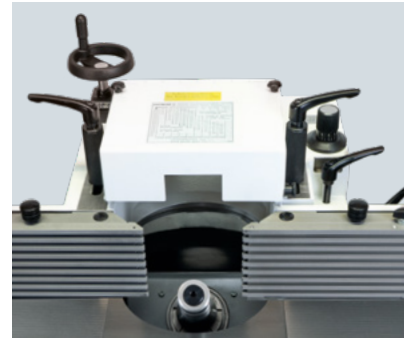

Fence type 2601 with integral fence jaws



Fence type 2601 with LED display

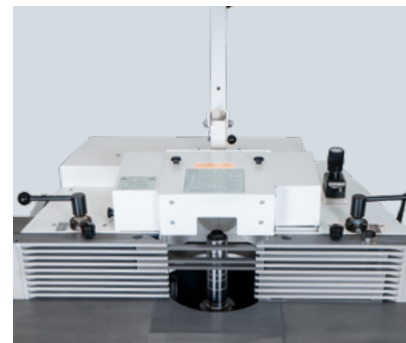

Fence type 2620 with integral fence jaws

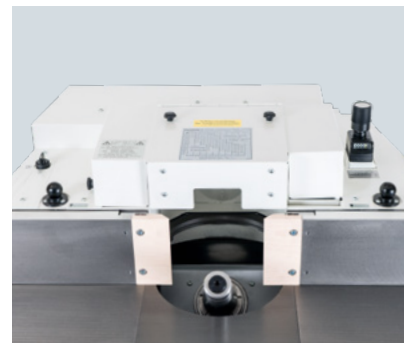

Fence type 2620 with air-lock and cast iron jaws



Guardian (the clamping of the jaws is monitored)



Milling arbor Duo standard or optionally with quick clamping nut



Collet chuck with a collect chuck nut

Technical changes reserved



Hofmannstr. 23 • 91438 Bad Windsheim



+49 (0) 9841 65 04 21



+49 (0) 9841 65 04 25



info@hofmann-maschinen.de



www.hofmann-maschinen.de



hofmann.maschinenfabrik



hofmann\_maschinenfabrik

## The top seller of the premium class

- unbeatable competitive!

The traditionally solid HOFMANN quality made of robust gray cast iron ensures maximum stability. Up to four axes can be moved electrically or selected via the modern CNC control. The table slide ensures the gap between the tool and table can be set quickly and easily. The swivel range of  $\pm 45.5^\circ$  (only TFS 1245) round off this premium machine. Many equipment options make this machine exactly the milling machine that suits you.

100 years of tradition - Quality "Made in Germany" - HOFMANN Maschinenfabrik is a family-run, medium-sized company with a 100-year tradition. 100 years of know-how and quality in the development and manufacture of woodworking machines. Our machines are produced exclusively in Germany. Whether planing, drilling or milling, at HOFMANN you are always well advised.



# Spindle Moulder

TF 1245 / TFS 1245



TF / TFS 1245 in standard or automatic version, here with table 1.2 m



TF / TFS 1245 in standard or automatic version, here with table 2.0 m



TF / TFS 1245 in version with CNC control here with table 2.7 m

## Special features

Our most diverse: Standard, automatic or CNC version

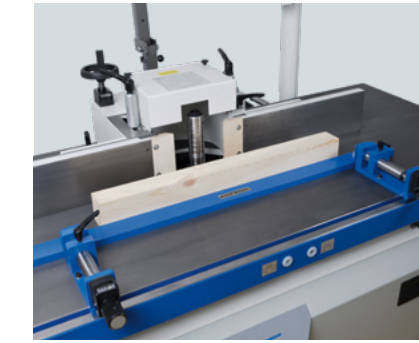

Counterstop

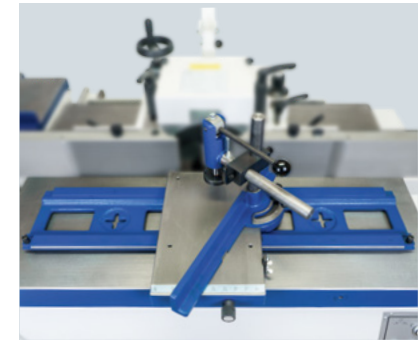

Sliding carriage



Function stand



Kick-back guard

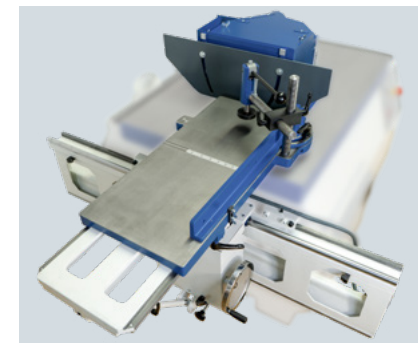

Sliding table with protective hood



Control panel for version standard / automatic



Control panel for version with CNC control; optional variable speed control for the feeder



Example mask for CNC control

Technical changes reserved

# Spindle Moulder

TF 1245 / TFS 1245

The top seller of the premium class - unbeatable competitive!

The traditionally solid HOFMANN cast iron quality is responsible for maximum stability and is complemented by unique construction methods, which guarantee best results in smooth running. The clever conceived control concept ensures that all control elements are intuitively reachable from the operating position. Short set-up times and simple operations provide a tremendously high level of efficiency. Swivel range from  $-45,5^\circ$  up to  $+45,5^\circ$

## Sketches

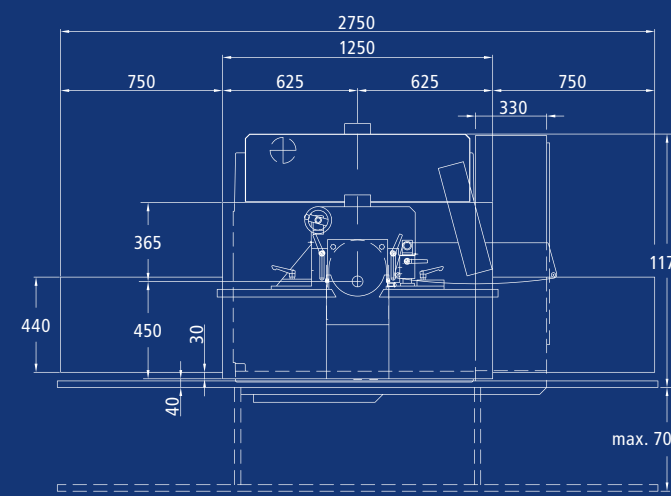
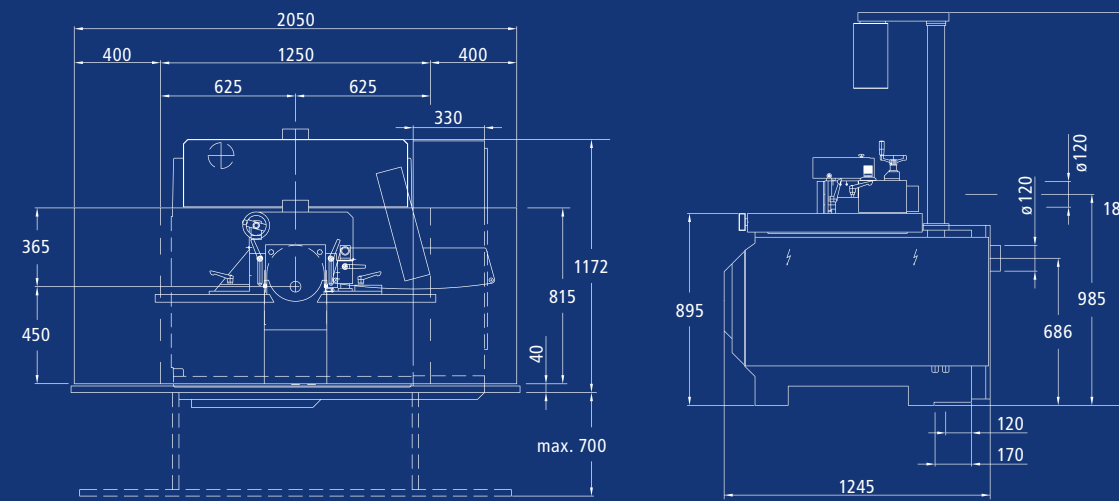

Technical changes reserved



Frame in cast iron and planed cast iron table

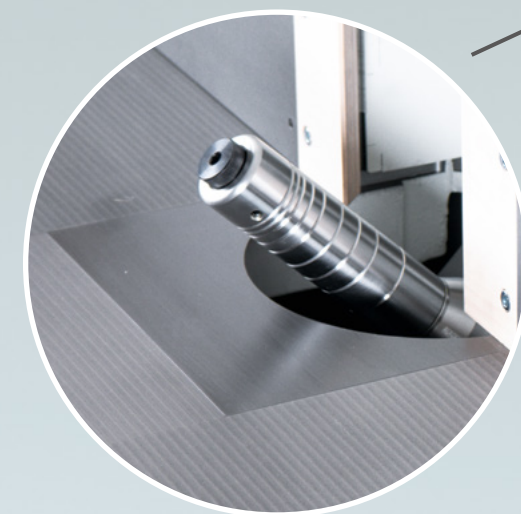
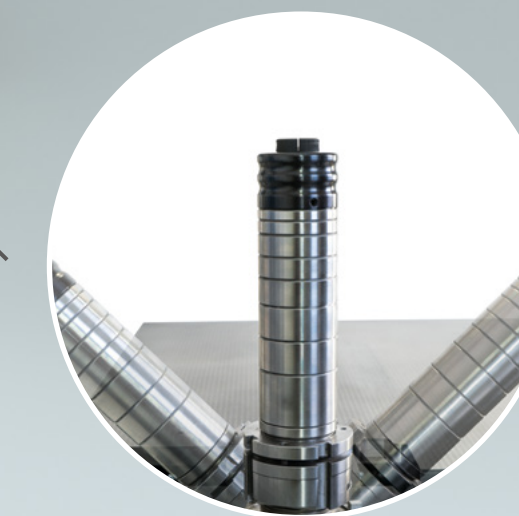

Table with table slide for quick and optimal adjustment of the table opening to the tool



Generous, modern control panel with 12.1" touch monitor



Rigid or swiveling spindle ( $45,5^\circ$  on both sides)

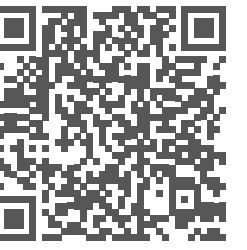

You can find more information about the TF / TFS1245 and our range of milling machines on our website. [www.hofmann-maschinen.de/en/produkte/frasen](http://www.hofmann-maschinen.de/en/produkte/frasen)

## Technical specifications

		TF / TFS 1245
Table size	mm	1.250 x 815
Table height	mm	895
Max. tool Ø	mm	250
Tilting range (TFS only)	mm	$-45,5^\circ$ bis $+45,5^\circ$
Arbor holder	—	MK 5
Standard speed	UpM	3.000 / 4.500 / 6.000 / 9.000
Optional: speeds variable	UpM	1.500 - 10.000
Power of motor	kW	7,5
Extraction nozzle (2 pieces) Ø	mm	120
Net weight approx.	kg	1.000