

Fence type 2620 with integral fence jaws

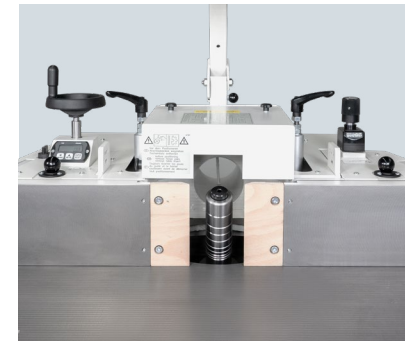

Fence type 2620 with cast fence jaws, AIR-LOCK

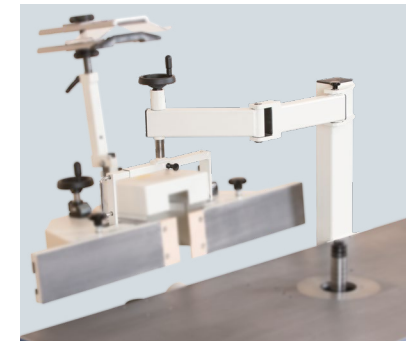

Swivel unit for fence



Milling arbor with quick release nut "fix"

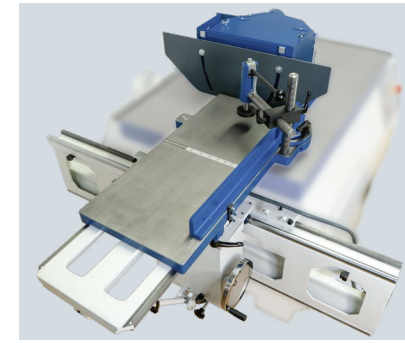

Rolling table with protective hood

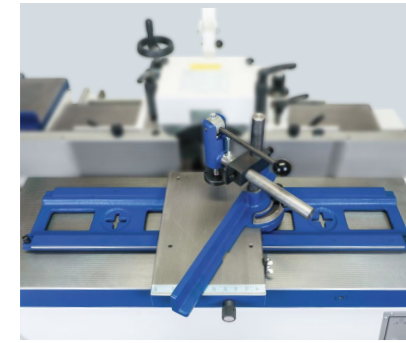

Sliding table



Kick-back guard



Shock protection



Guardian (the clamping of the fence jaws is monitored)



Safety light strip on fence



Tool compartment



Collet chuck with collet

Subject to technical changes



-  Hofmannstr. 23 • 91438 Bad Windsheim
-  +49 (0) 9841 65 04 21
-  +49 (0) 9841 65 04 25
-  info@hofmann-maschinen.de
-  www.hofmann-maschinen.de
-  hofmann.maschinenfabrik
-  hofmann\_maschinenfabrik

## 100 years of tradition – quality "Made in Germany"

HOFMANN Maschinenfabrik is a family-run, medium-sized company with a 100 years of tradition. 100 years of know-how and quality in the field of development and production of woodworking machines.

Our machines are produced exclusively in Germany, in the heart of the idyllic Franconia Bad Windsheim. For the production of our machines we only use high quality materials from renowned suppliers. These materials are processed and assembled by our committed employees in modern production facilities. The machines only leave after several quality controls the house and are delivered to the customer - worldwide.

Whether planing, drilling or milling, at HOFMANN you are always well advised.



## Spindle moulder TFS 107



TFS 107 in basic configuration with table 1.2 m



TFS 107 with options with table 2 m



TFS 107 with options with table 2.7 m

## Highlights

Solid spindle moulder at an affordable price



Control panel in basic configuration

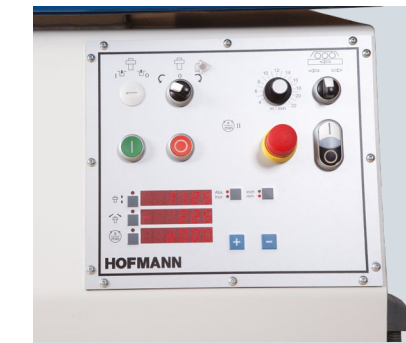

Control panel with variable spindle speed – with option of gradual feed speed



Optional: Console on top

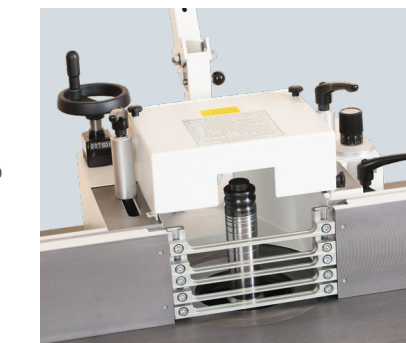

Fence type 2601 efficient with cast bolsters, safety rulers



Fence type 2601 efficient with Aigner integral bolster



Fräsanschlag Typ 2601 with LCD display

Subject to technical changes

# Spindle moulder

TFS 107

Our "little big one" – a lot of machine for little money!

100 % Made in Germany – this milling machine attracts through a solid basic configuration at an interesting price. It offers a swivel range from  $-45,5^\circ$  to  $+45,5^\circ$ , motor-driven spindle adjustment with LED display, 7,5 kW motor with 4 speeds, clockwise/counter-clockwise rotation of spindle and much more.

T perfect basis for reliable work.

## Sketches

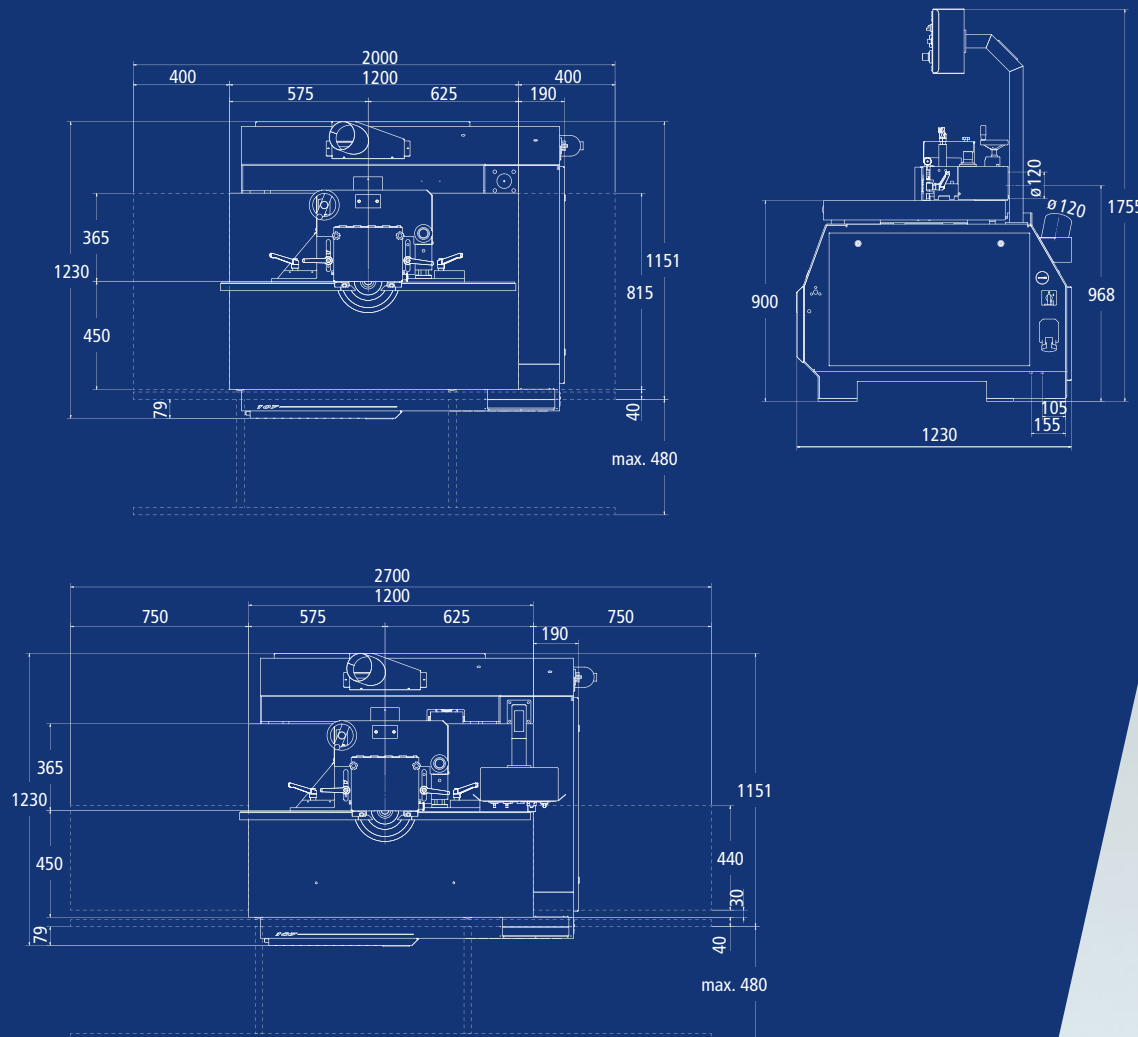

Subject to technical changes



Swivel range  
double-sided  $45,5^\circ$

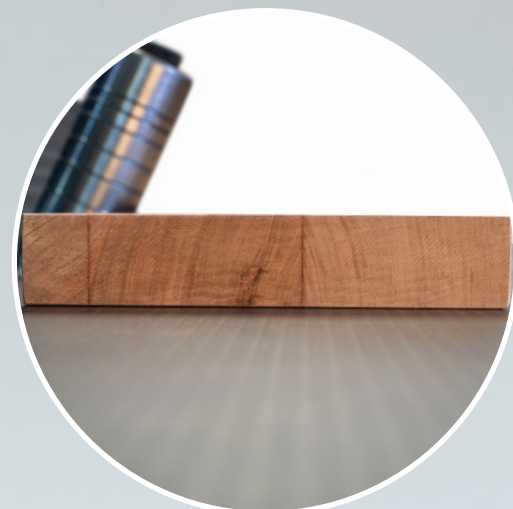

Planned cast tables

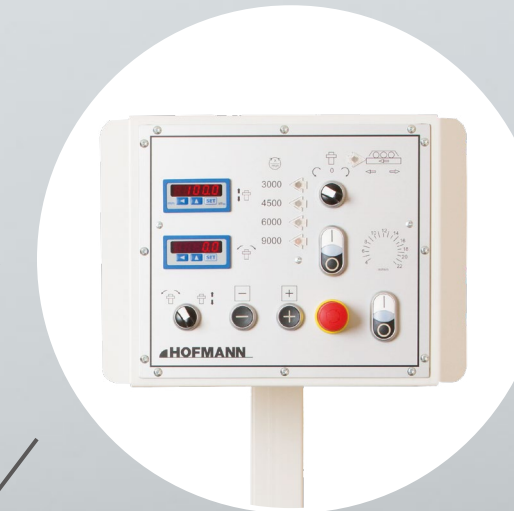

Control panel  
optional under or above table



Motor-driven adjustment  
for height and angle

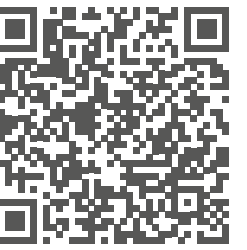

More information about the TFS107 and our milling machine range can be found on our website.  
[www.hofmann-maschinen.de/produkte/frasen](http://www.hofmann-maschinen.de/produkte/frasen)

## Technical specifications

		TFS 107
Table size	mm	1200 x 815
Table height	mm	900
Table insert opening	Ø	65 / 100 / 140 / 200 / 250
Height adjustment milling arbor approx.	mm	ca. 145
Swivel range milling arbor	mm	$-45,5^\circ$ bis $+45,5^\circ$
Speed	rpm	3.000 / 4.500 / 6.000 / 9.000
Power of motor	kW	7,5
Extraction nozzle (2 units)	mm Ø	120
Average air speed	m/s	20
Weight approx.	kg	820